

DK04-P

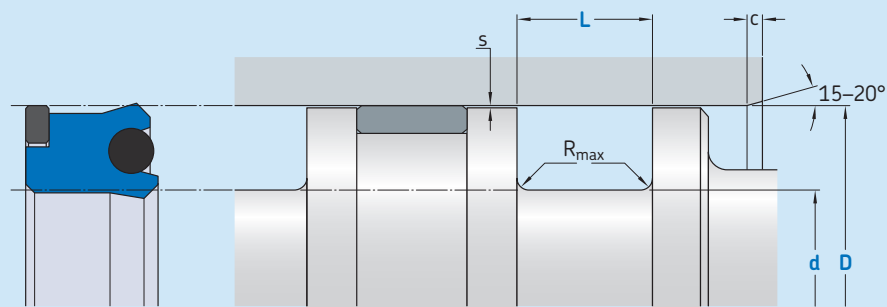

Ordering dimensions in **blue**

Surface roughness	R_{tmax}	R_a
Sliding surface	$\leq 2,5 \mu\text{m}$	$0,05\text{--}0,2 \mu\text{m}$
Bottom of groove	$\leq 6,3 \mu\text{m}$	$\leq 1,6 \mu\text{m}$
Groove face	$\leq 15 \mu\text{m}$	$\leq 3 \mu\text{m}$

Bearing area: 50–95% and a cutting depth of $0,5 R_z$ based on $C_{ref} = 0\%$

Standard dimensions

D H9 over	d h10 incl.	L + 0,2	R_{max}	c	$s^1)$	Maximal radial extrusion gap			
						20 bar	100 bar	400 bar	700 bar
mm						mm			
13	25	D – 8	6,0	0,4	3,5	0,80	0,80	0,30	0,04
25	50	D – 10	7,0	0,4	4,0	1,00	1,00	0,37	0,04
50	75	D – 12	8,0	0,4	4,5	1,25	1,24	0,42	0,05
75	150	D – 15	10,0	0,4	5,0	1,50	1,47	0,46	0,05
150	200	D – 20	12,0	0,4	6,0	2,00	1,77	0,54	0,06

¹⁾ Extrusion gap values shown above are valid for a temperature of 70 °C, higher temperatures require lower values.

²⁾ Please contact SKF.

Ordering example

Profile
D x d x L [mm]
Sealing material / Energizer / Backup ring

Piston seal DK04-P
100 x 85 x 10
ECOPUR DD / NBR70 / SKF Ecotal

Operating parameters

Material Seal	Energizer	Back-up ring	Temperature		Speed ¹⁾	Pressure ²⁾
			from	to	max	max
–			°C		m/s	bar (MPa)
■ ECOPUR DD	NBR70	■ SKF Ecotal	–30	+100	0,5	700 (70)

IMPORTANT NOTE: The stated operating conditions represent general indications. It is recommended not to use all maximum values simultaneously.

¹⁾ Surface speed limit values are valid only in the presence of a lubrication film.

²⁾ Pressure ratings depend on the size of the extrusion gap.