

DK02-R

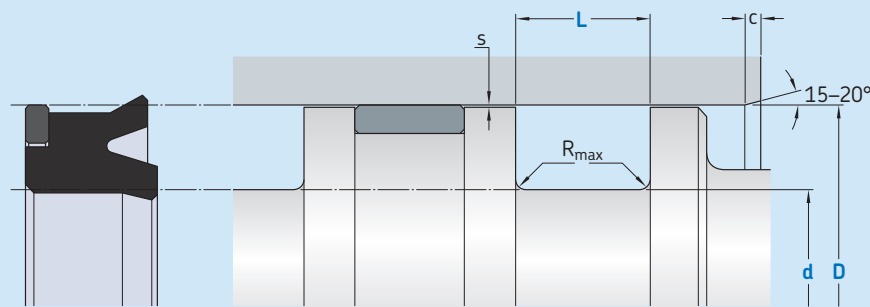

Ordering dimensions in **blue**

Surface roughness	R_{tmax}	R_a
Sliding surface	$\leq 2,5 \mu m$	0,05–0,2 μm
Bottom of groove	$\leq 6,3 \mu m$	$\leq 1,6 \mu m$
Groove face	$\leq 15 \mu m$	$\leq 3 \mu m$

Bearing area: 50–95% and a cutting depth of 0,5 R_z , based on $C_{ref} = 0\%$

Standard dimensions						Maximal radial extrusion gap		
D	d	L	R_{max}	c	$s^{1)}$			
H9	h10	+ 0,2				20 bar	100 bar	250 bar
over	incl.							
mm						mm		
13	25	D – 8	6,0	0,4	3,5	0,80	0,80	0,52
25	50	D – 10	7,0	0,4	4,0	1,00	1,00	0,66
50	75	D – 12	8,0	0,4	4,5	1,25	1,20	0,72
75	150	D – 15	10,0	0,4	5,0	1,50	1,40	0,78
150	200	D – 20	12,0	0,4	6,0	2,00	1,66	0,88

¹⁾ Extrusion gap values shown above are valid for a temperature of 70 °C, higher temperatures require lower values.

Ordering example

Profile
D x d x L [mm]
Sealing material / Backup ring

Piston seal DK02-R
100 x 85 x 10
SKF Econbr / SKF Ecotal

Operating parameters

Material Seal	Back-up ring	Temperature		Speed ¹⁾	Pressure ²⁾
		from	to	max	max
		°C		m/s	bar (MPa)
■ SKF Econbr	■ SKF Ecotal	-30	+100	0,5	250 (25)
■ SKF Ecofkm	■ SKF Ecoptfe	-20	+200	0,5	250 (25)

IMPORTANT NOTE: The stated operating conditions represent general indications. It is recommended not to use all maximum values simultaneously.

¹⁾ Surface speed limit values are valid only in the presence of a lubrication film.

²⁾ Pressure ratings depend on the size of the extrusion gap.